

Model 611608421

C-band X-Pol (Type N) Feed Assembly

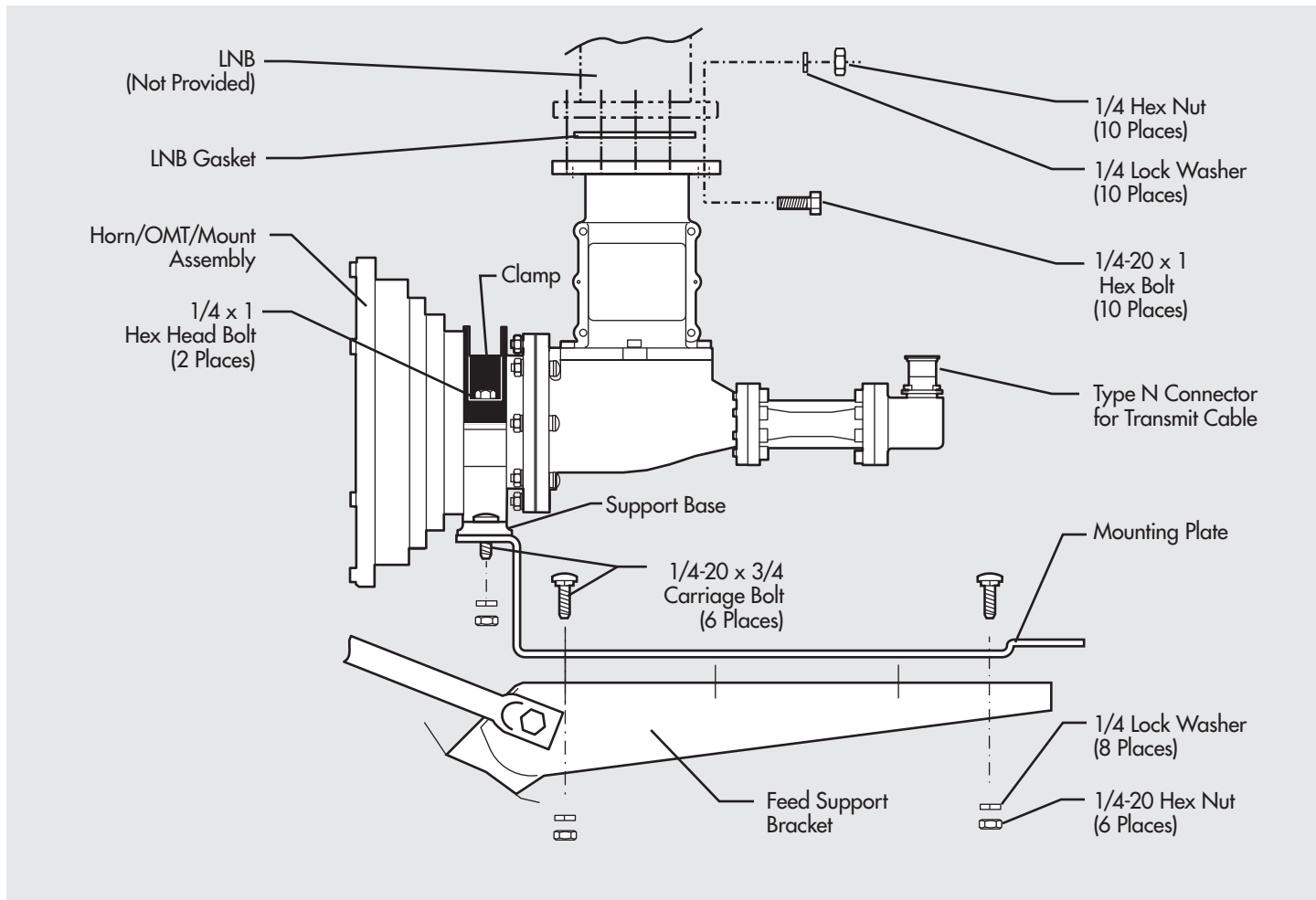

Assemble mounting plate to support base as shown. Assemble feed assembly with mounting plate to feed support bracket as shown. To rotate for polarity, loosen two 1/4" clamp bolts and rotate horn/OMT assembly. Mark on top clamp aligns with polarity on horn scale.

Retighten and torque hardware as follows:

- Torque all #8 screws to 9.5 in-lb.
- Torque all #10 hex bolts to 23 in-lb.
- Torque all 1/4 bolts to 72 in-lb.



DO NOT DISCARD CONTENTS

The product in this packaging was placed in the market after August 13, 2005. Its components must not be discarded with normal municipal or household waste. Contact your local waste disposal agency for recovery, recycling, or disposal instructions.



Model 611618421

C-band X-Pol (WR 137) Feed Assembly

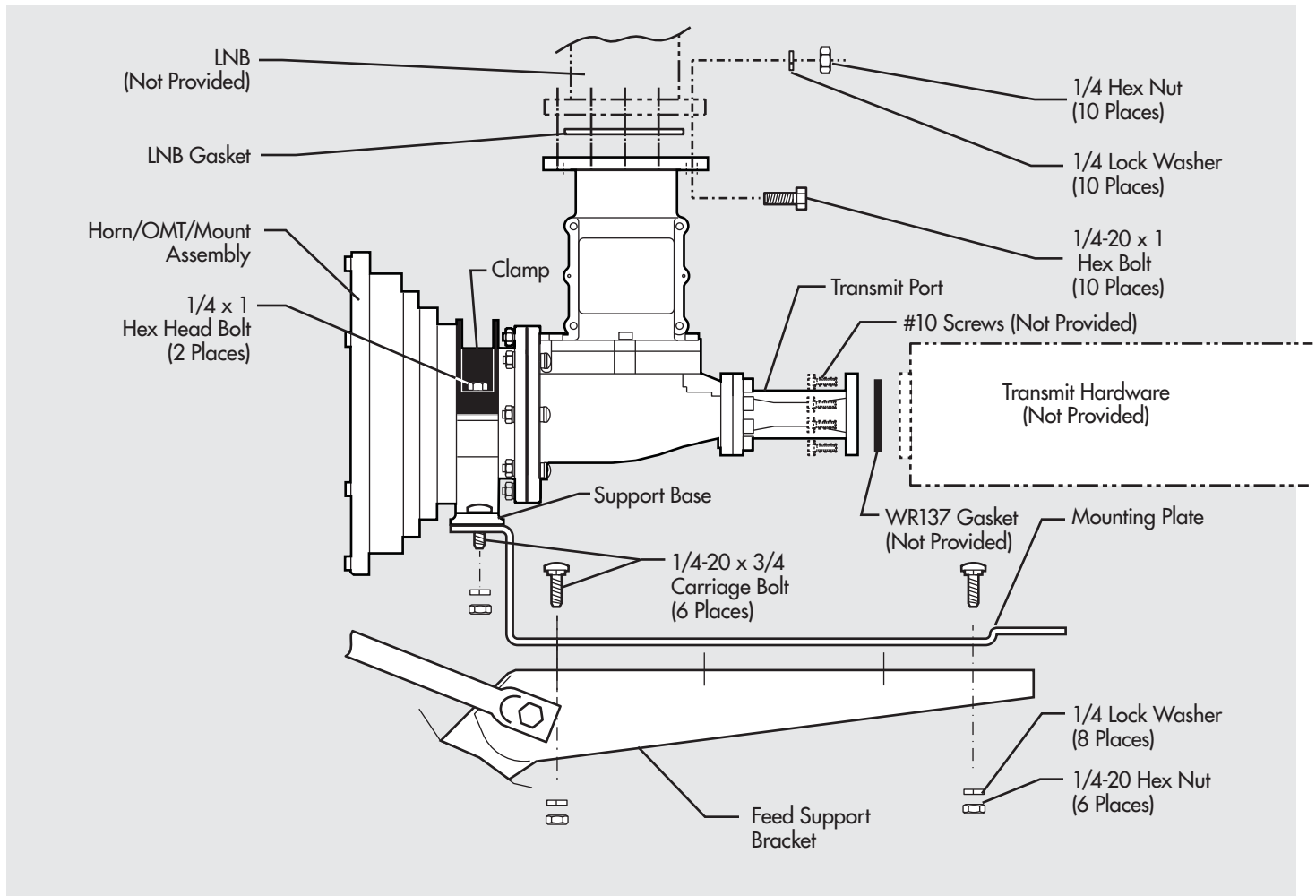

Assemble mounting plate to support base as shown. Assemble feed assembly with mounting plate to feed support bracket as shown. To rotate for polarity, loosen two 1/4" clamp bolts and rotate horn/OMT assembly. Mark on top clamp aligns with polarity on horn scale.

Retighten and torque hardware as follows:

- Torque all #8 screws to 9.5 in-lb.
- Torque all #10 hex bolts to 23 in-lb.
- Torque all 1/4 bolts to 72 in-lb.

